

SCOUT TRANSPORT CART

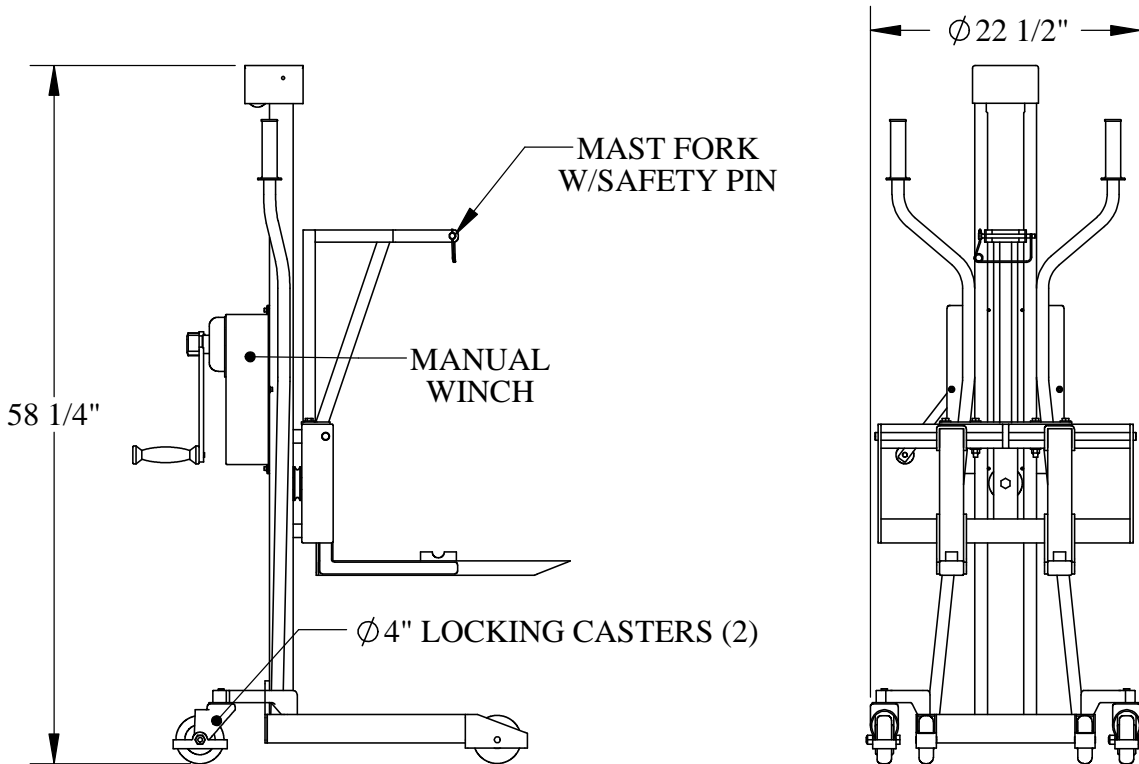

SPECIFICATIONS:

THE AQUA CREEK SCOUT TRANSPORT CART SHALL BE A MANUAL-WINCH POWERED TRANSPORT CART WITH CAPTURE-BARS DESIGNED TO BE USED IN THE SAFE REMOVAL AND TRANSPORT OF THE SCOUT LIFT. THE CART SHALL BE EASILY OPERABLE BY ONE PERSON, AND SHALL HOLD THE SCOUT LIFT SECURELY AND STEADILY FOR TRANSPORT AND STORAGE. IT SHALL BE CONSTRUCTED PRIMARILY OF POWDER-COATED STEEL AND STAINLESS STEEL, AND SHALL INCLUDE 4" LOCKING CASTERS.

MAIN ASSEMBLY: POWDER COATED CARBON STEEL
 MAST-FORK ASSY: POWDER COATED 304L STAINLESS STEEL
 CASTERS: 4" LOCKING POLYOLEFIN
 FRONT WHEELS: 3.5" POLYETHYLENE

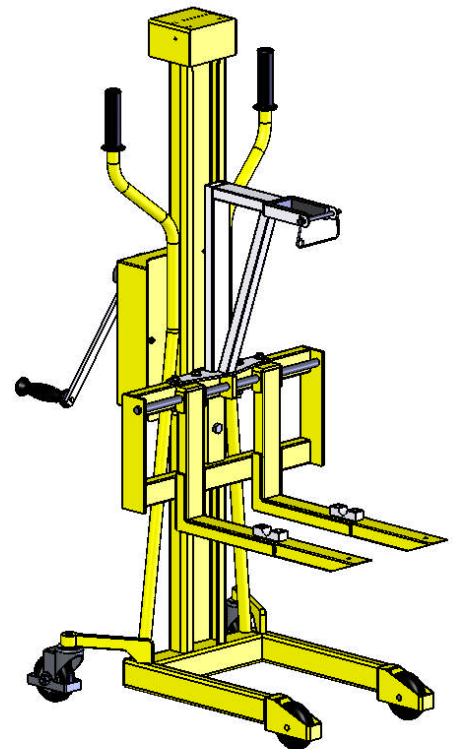

9889 GARRY MORE LANE
 MISSOULA, MT 59808
 (406) 549-0769
 FAX (406) 549-2602

NOTE:
 *SPECIFICATIONS ARE SUBJECT TO CHANGE WITHOUT NOTICE
 *ALL DIMENSIONS ARE IN INCHES

PRODUCT:	F-814SCTC	
DWG #:	F-814SCTC-1	
SCALE:	1:18	DATE: 6/27/11
DRAWN BY:	DS	REVISION: A