

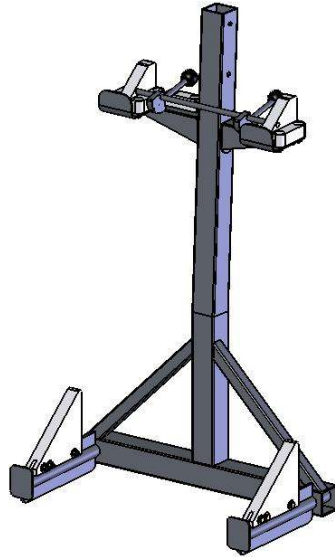

Aqua Creek Products

The Total Solution for Pool and Spa Access



REVOLUTION WHEELCHAIR PICKER

500LB [227 kg] MAXIMUM CAPACITY

MANDATORY – LEAVE THIS MANUAL WITH OWNER



- WARNING -

IMPORTANT SAFETY INSTRUCTIONS

1. READ AND FOLLOW ALL INSTRUCTIONS. LIFT SAFETY CAN ONLY BE ENSURED IF THE LIFT IS INSTALLED AND OPERATED PROPERLY – ACCORDING TO THESE INSTRUCTIONS.
2. TO REDUCE THE RISK OF INJURY, DO NOT PERMIT CHILDREN TO USE THIS PRODUCT UNLESS THEY ARE CLOSELY SUPERVISED AT ALL TIMES.
3. DO NOT PERMIT CHILDREN TO PLAY ON OR AROUND THIS PRODUCT.
4. NEVER APPLY DIRECT WATER PRESSURE TO THE ELECTRONIC COMPONENTS.
5. SAVE A COPY OF THESE INSTRUCTIONS IN A SAFE AND EASILY ACCESSIBLE PLACE.

AQUA CREEK PRODUCTS
9889 GARRYMORE LANE
MISSOULA, MT 59808
1-888-687-3552
FAX: 406-549-2602

INSTALLATION INSTRUCTIONS:

To install the Wheelchair Picker onto the Revolution lift;

- 1] Raise the Revolution lift to its highest position.
- 2] Remove the two (2) 3/8" hex bolts from the seat arm, and slide the seat/seat cradle off of the seat arm.
- 3] Slide the Wheelchair Picker onto the seat arm, and using the supplied 5/16" CLIP-PINS, pin it to the 2nd highest position on the seat arm. This will put the top pin in the 5th hole from the bottom (see **FIGURE 1**).
- 4] Close the clips to lock the pins in place.

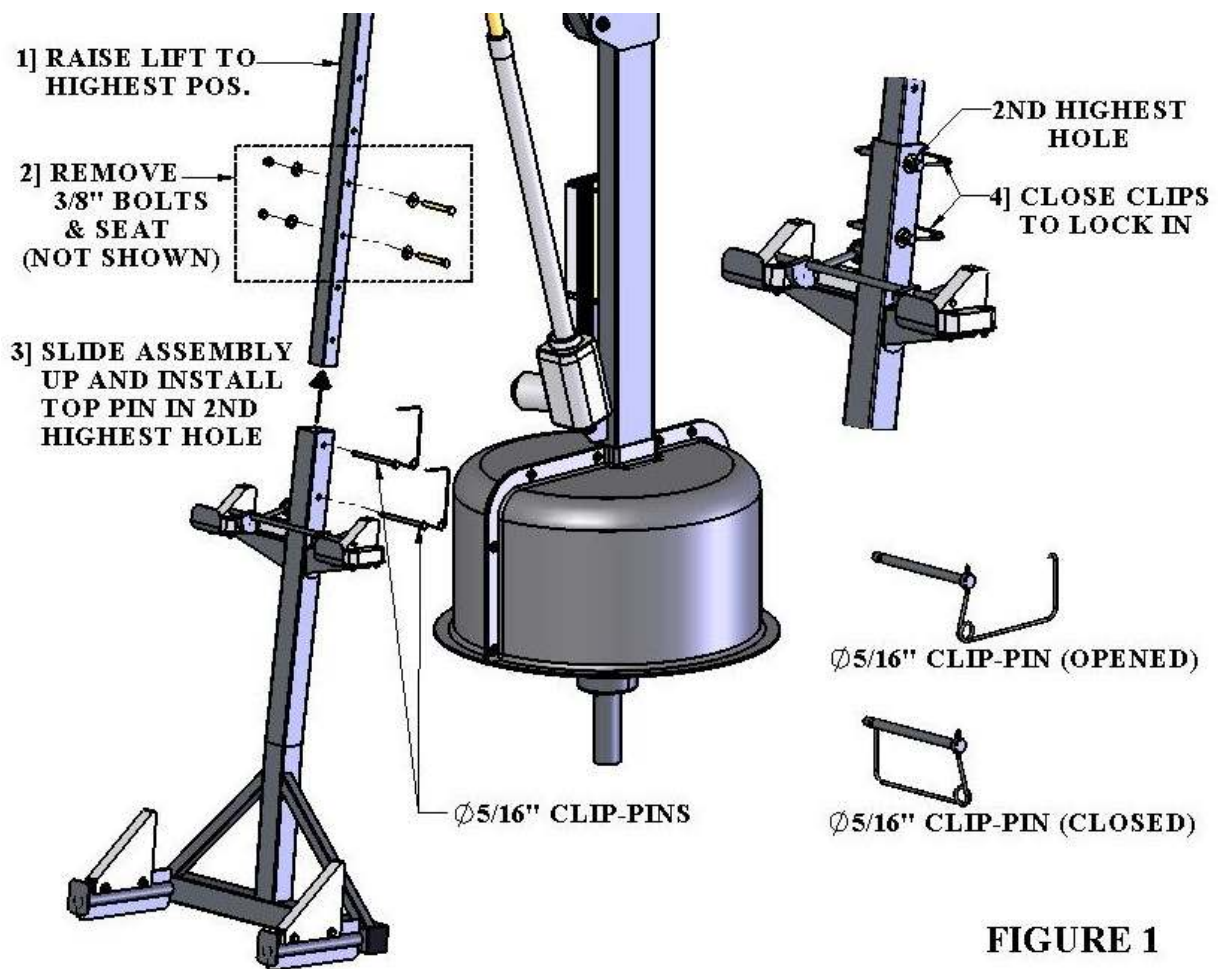

NOTE: BECAUSE OF THE HEIGHT OF THE WHEELCHAIR PICKER IT WILL BE NECESSARY TO ROTATE THE LIFT OVER THE POOL/SPA BEFORE THE ASSEMBLY CAN BE ATTACHED TO THE SEAT ARM.

OPERATING INSTRUCTIONS:

In order to use the Wheelchair Picker as intended there must be ample space on the deck to back the wheelchair onto the Wheelchair Picker's fork assembly.

1. To begin the loading sequence, line up the wheelchair's handle center to the center of the Wheelchair Picker.
2. Then lower the lift until the fork is below the back bar of the wheelchair (almost touching the floor/deck).
3. Next roll the wheelchair over the fork until it touches the Wheelchair picker.
4. Push the UP button on the handset and raise the wheelchair – AT THIS POINT MAKE SURE THE WHEELCHAIR IS BACK AS FAR AS IT CAN GO TO ENSURE CAPTURE OF THE WHEELCHAIR BY THE PICKER. Raise the lift until the wheelchair locks into the picker assembly.
5. Raise the lift all the way up and then rotate the lift over the pool/spa.
6. Lower the lift/wheelchair into the water.

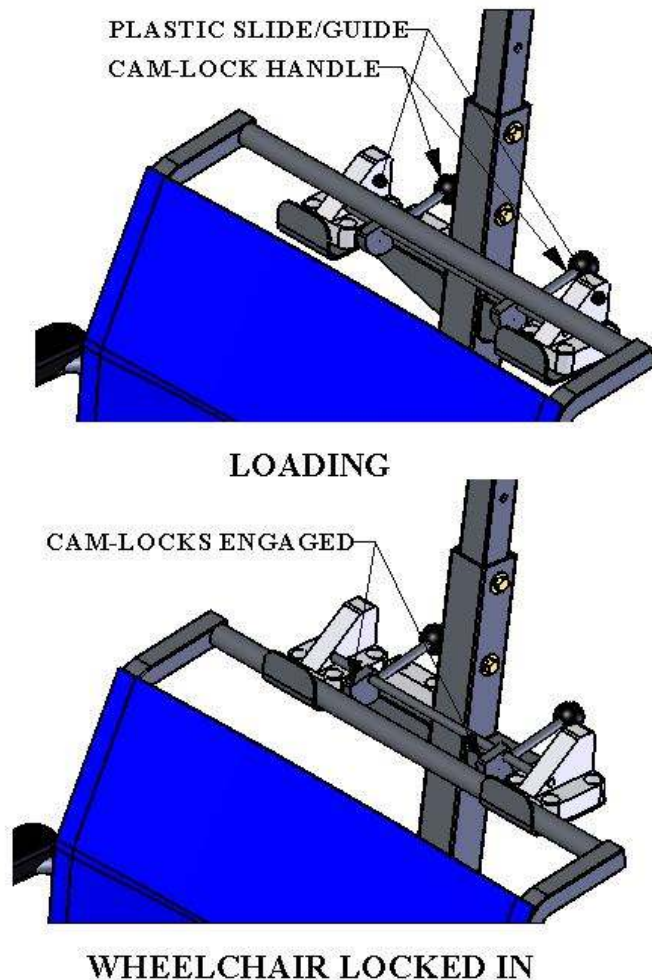

FIGURE 2

FIGURE 3

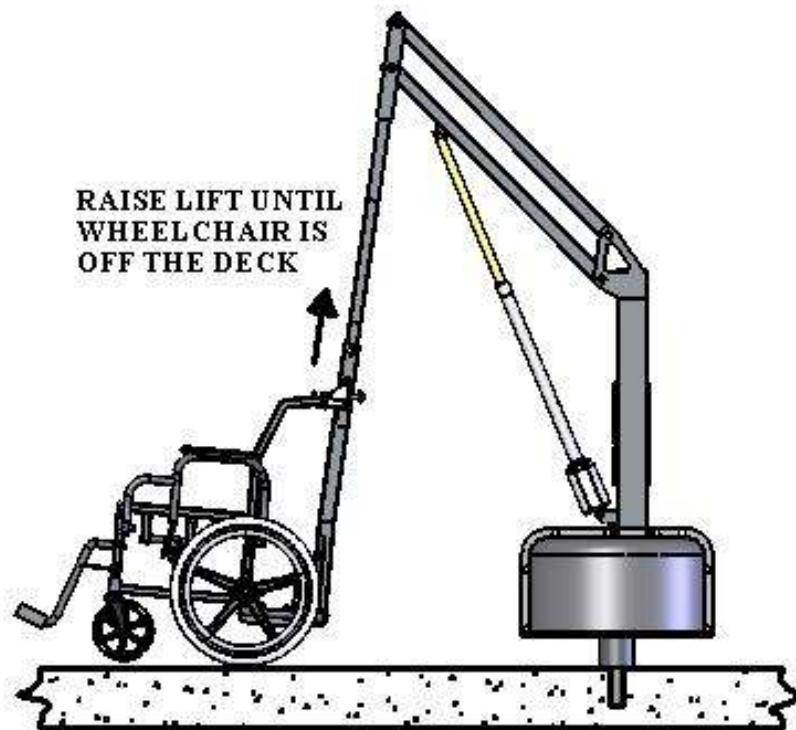
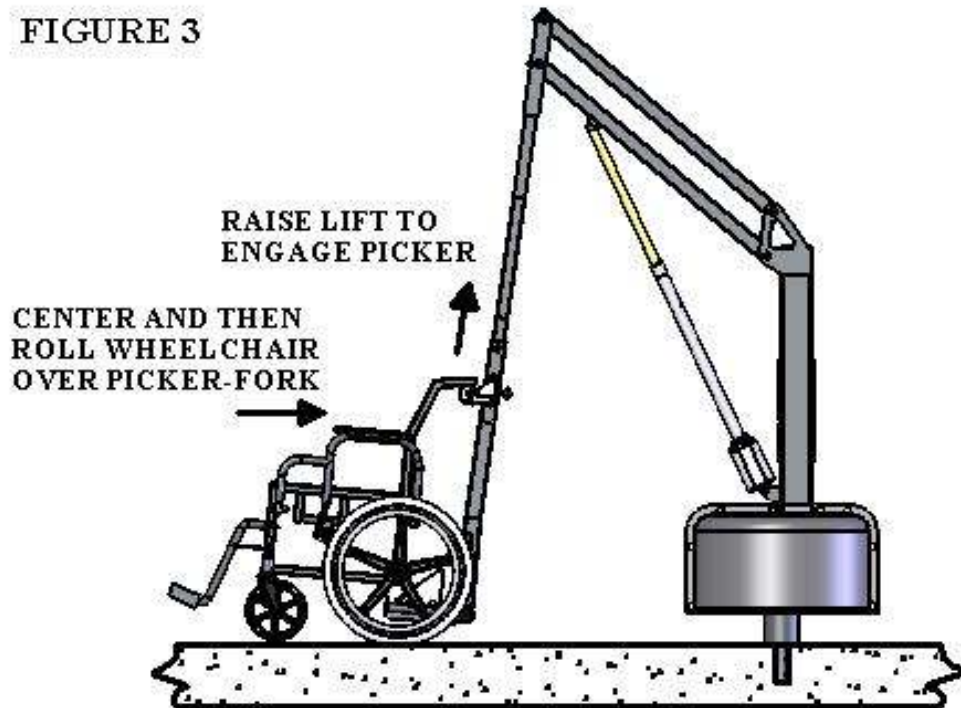
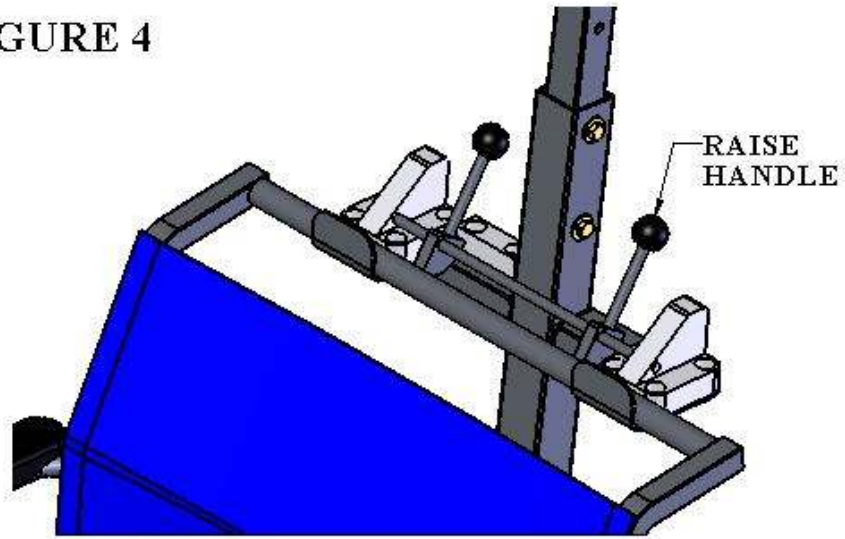
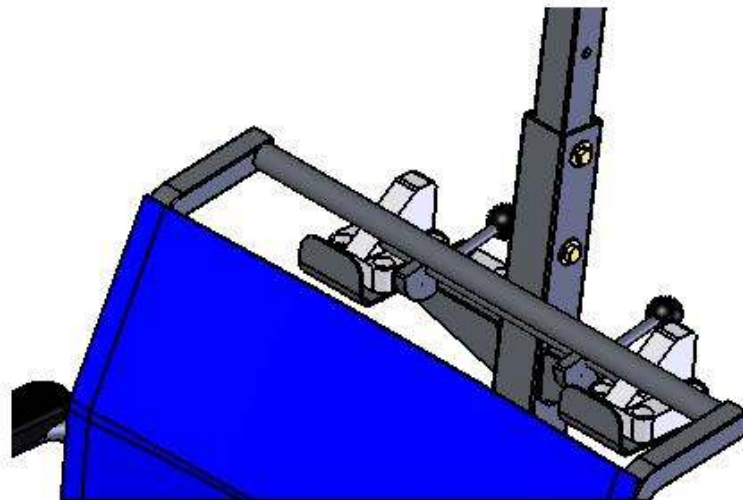

FIGURE 4



RAISE HANDLES TO UNLOCK



LOWER LIFT AND ROLL AWAY

Aqua Creek Products, LLC Limited Warranty:

REVOLUTION WHEELCHAIR PICKER

Aqua Creek Products lifts have a **Limited Lifetime Warranty** on the frames, not including the powder coat finish. Aqua Creek Products, LLC (a.k.a. Aqua Creek) also warrants to the original end user that all non-frame components manufactured by Aqua Creek, when properly installed in accordance with assembly and installation instructions, and properly used and maintained, shall be free from defects in material and workmanship for a period of five (5) years from the date of original purchase, provided that Aqua Creek receives prompt notice in writing of any defect or failure and satisfactory proof thereof, with the following exceptions:

Exception : The wheelchair shall have a warranty period of five (5) years on the frame and parts and a warranty period of two (2) years on the upholstery.

This warranty specifically excludes reimbursement for labor to remove, repair, or install the product and any return freight charges. These warranties do not cover any damages due to accident, misuse, abuse, negligence or failure to properly maintain any products, or normal wear and tear from day to day operations. In the event that any products are altered, repaired, or improperly installed or improperly used by anyone without the prior written approval by Aqua Creek, all warranties are void. **IMPORTANT: AMOUNT OF WEIGHT PLACED ON LIFT SHALL NOT EXCEED THE RATED LIFTING CAPACITY OF 500 POUNDS [227 kg] FOR THE WHEELCHAIR PICKER.**

To initiate a warranty claim, the owner of an Aqua Creek product must provide the place of purchase, in writing, with a full description of the product, its serial number, the dates of purchase and installation, and the exact nature of the defect. Within thirty (30) days after receipt of a written warranty claim by Aqua Creek, and barring any unforeseen delays, the place of purchase will be notified of Aqua Creek's decision regarding the claim.

If requested by Aqua Creek, any defective product must be returned, freight prepaid, to Aqua Creek's designated factory location or duly appointed distributor for inspection and/or repair. Aqua Creek will, at its option, repair or replace the failed or defective item, and deliver the repaired product or replacement to the buyer of the product, freight prepaid to the destination provided for in the original order. Products returned to Aqua Creek for which Aqua Creek provides replacement under this limited warranty shall become the property of Aqua Creek.

A new warranty period shall NOT be established for the repaired or replaced products. Such products shall remain under warranty only for the remainder of the original warranty period on the original products purchased.

This written limited warranty constitutes the final, complete and exclusive statement of warranty terms. No person or organization is authorized to make any other specific or implied warranties or representations on behalf of Aqua Creek.

THE WARRANTIES SET FORTH HEREIN ARE IN LIEU OF ALL OTHER WARRANTIES, EXPRESSED OR IMPLIED, WHICH ARE HEREBY DISCLAIMED AND EXCLUDED, INCLUDING WITHOUT LIMITATION ANY WARRANTY OF MERCHANTABILITY OR FITNESS FOR A PARTICULAR PURPOSE OR USE.

THE SOLE AND EXCLUSIVE REMEDIES FOR BREACH OF ANY AND ALL WARRANTIES WITH RESPECT TO THE PRODUCTS SHALL BE LIMITED TO REPAIR OR REPLACEMENT AT AQUA CREEK'S DESIGNATED FACTORY LOCATION, OR DULY APPOINTED DISTRIBUTOR, OR IN PLACE AT AQUA CREEK'S OPTION. IN NO EVENT SHALL AQUA CREEK'S LIABILITY EXCEED THE ENTIRE AMOUNT PAID TO AQUA CREEK BY THE ORIGINAL PURCHASER FOR THE FAILED OR DEFECTIVE PRODUCT.

IN NO EVENT SHALL AQUA CREEK PRODUCTS, LLC BE LIABLE FOR ANY INCIDENTAL, CONSEQUENTIAL, SPECIAL, INDIRECT, PUNITIVE OR EXEMPLARY DAMAGES OR LOST PROFITS FROM ANY BREACH OF THIS LIMITED WARRANTY OR OTHERWISE.

Aqua Creek Products
9889 Garrymore Lane
Missoula, MT 59808