



Aqua Creek Products

The Total Solution for Pool and Spa Access

INSTALLATION AND OPERATING INSTRUCTIONS

PRO POOL LIFT™ REVERSED BASE

MODEL # F-004PLB-R

450 LB. [204kg] MAXIMUM CAPACITY (PRO POOL-R LIFT)

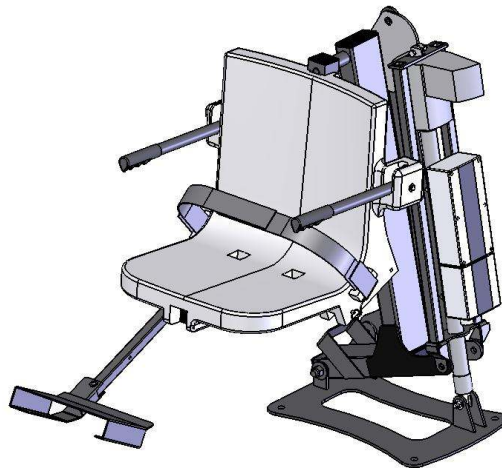

- WARNING -

IMPORTANT SAFETY INSTRUCTIONS

- 1. READ AND FOLLOW ALL INSTRUCTIONS. LIFT SAFETY CAN ONLY BE ENSURED IF THE LIFT IS INSTALLED AND OPERATED PROPERLY – ACCORDING TO THESE INSTRUCTIONS.**
- 2. TO REDUCE THE RISK OF INJURY, DO NOT PERMIT CHILDREN TO USE THIS PRODUCT UNLESS THEY ARE CLOSELY SUPERVISED AT ALL TIMES.**
- 3. DO NOT PERMIT CHILDREN TO PLAY ON OR AROUND THIS PRODUCT.**
- 4. NEVER APPLY DIRECT WATER PRESSURE TO THE ELECTRONIC COMPONENTS.**
- 5. SAVE A COPY OF THESE INSTRUCTIONS IN A SAFE AND EASILY ACCESSIBLE PLACE.**

AQUA CREEK PRODUCTS
9889 GARRYMORE LANE
MISSOULA, MT 59808
1-888-687-3552
FAX: 406-549-2602

Inspected And Verified To Meet
Applicable Sections of ADA
Guidelines Section 1009.2 By

wyle
laboratories

A Nationally Recognized
Test Laboratory

PRO POOL LIFT™

PARTS LIST

1. PRO POOL LIFT™ W/ FOOTREST
2. HARDWARE BAG
3. INSTALLATION INSTRUCTIONS
4. 24V BATTERY
5. BATTERY CHARGER W/ MOUNTING PLATE
6. WATERPROOF CONTROLLER
7. ANCHOR BOLT BAG (SET OF 4)
8. ANCHOR JIG PLATE



HARDWARE BAG – PRO POOL LIFT			
ITEM #	QTY.	DESCRIPTION	PART USE / LOCATION
1	4	1/2 x 1-1/2" HEX HEAD BOLT S.S.	LIFT ANCHOR BOLTS
2	4	1/2" NYLON FLAT WASHER S.S.	LIFT ANCHOR BOLTS & ACTUATOR
3	1	SEAT BELT	CHAIR
4	1Me	ANTI-SEIZE CREAM	

INSTALLATION: ADA GUIDELINES

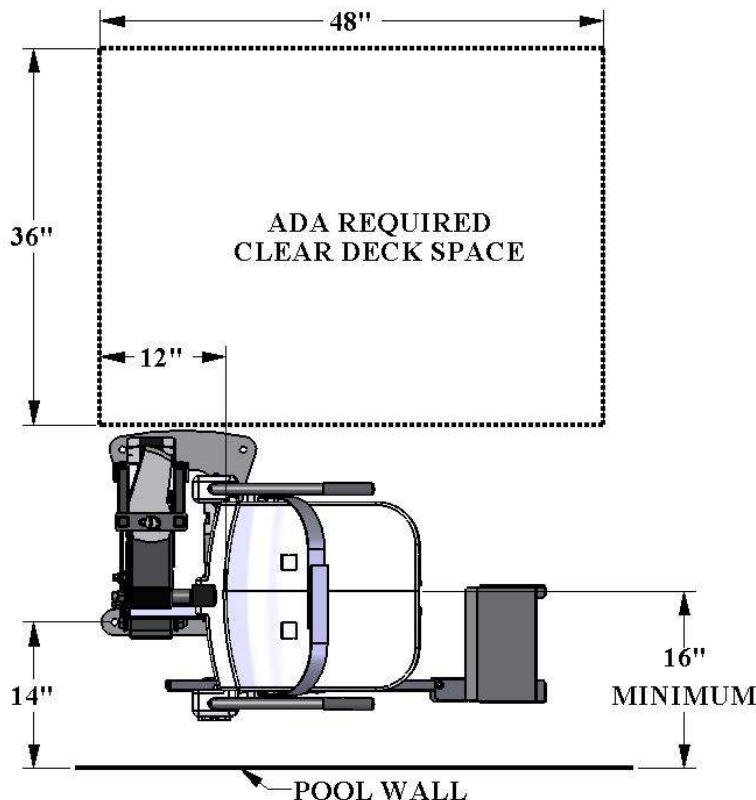

ADA REQUIREMENTS:

The PRO POOL LIFT™ is designed and manufactured to be 100% ADA compliant. But for the installed lift to be 100% compliant the installation must meet the requirement for CLEAR DECK SPACE as shown in the diagram to the left. To be compliant, install the lift at 14 inches [357mm] (the maximum setback) from the pool edge, and make sure the deck has the required CLEAR DECK SPACE as shown.

PRO POOL LIFT: 4 –POINT ANCHOR INSTALLATION

NOTE: THE PRO POOL LIFT ANCHOR CAN BE INSTALLED IN EITHER A NEW POOL DECK OR AN EXISTING DECK.

RETRO-FIT INSTALLATION / EXISTING DECK APPLICATION

TOOLS REQUIRED:

MARKING PEN/PENCIL

2" CORE DRILL BIT

POWER DRILL

LEVEL

HIGH STRENGTH ANCHOR ADHESIVE*

HAMMER & CHISEL

1. Locate the anchor jig and the FOUR (4) anchor bolts. **FIGURE 1**
2. Using the anchor jig plate smaller holes as a template, mark the FOUR (4) hole locations on the deck. The front anchor must be no more than 14 inches [356mm] from the pool wall. **FIGURE 3**. Make sure to keep the two rear anchor holes parallel to the pool wall.
3. Remove the 1" hex nuts from the anchor bolts. Core Drill a 1-1/4" [32mm] diameter hole at the FOUR (4) locations marked from step 1. Drill to a depth of 4" to 5" [10cm to 13cm].
4. Remove the core from the hole with a chisel and hammer if necessary. Clean out all four holes completely.
5. Fill each hole approximately 1/2 full with high strength anchor adhesive.*
6. Ground at least one anchor bolt to an existing bonding grid or appropriate ground source per local codes.
7. Install the FOUR (4) anchor bolts into the epoxy filled holes. Make sure that the top of the bolts will be flush with the top of the pool deck. (NOTE: To make positioning of the anchors easier the 1/2" bolts may be temporarily installed in the anchors to give you something to hold onto.)
8. Let the adhesive cure as per the manufacturer's instructions before installing the PRO POOL LIFT™.

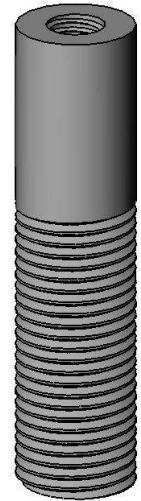

**FIGURE 1
(ANCHOR BOLT,
HEX NUTS
REMOVED)**

* Use **HILTI HIT HY-150** or **SIMPSON ET22 StrongTie** anchor adhesive or equivalent.

NEW CONSTRUCTION: ANCHOR INSTALLATION

When the lift is installed on a new deck, the slab should be a minimum of 6" [15cm] thick at the lift location, and should be reinforced with #4 reinforcing bar at 10" [25.4cm] on center in each direction. The total pad area should be 3 feet [92cm] wide (from the edge of the pool back) by 3 feet [92cm] long.

1. Locate the preset anchor jig assembly and the four (4) anchor bolts. Mount the anchor bolts to the jig plate as shown in **FIGURE 2**.
2. Ground the jig plate using the attached bronze grounding lug. Check local codes for anchor grounding.
3. Locate the jig assembly at the desired pool location. The front anchor (centerline) must be no more than 14" [35.6cm] from the pool wall as shown in **FIGURE 3**. Make sure to keep the front two anchor holes parallel to the pool wall.
4. Make sure the anchor assembly is plumb and level – secure the anchors, and then pour the deck.

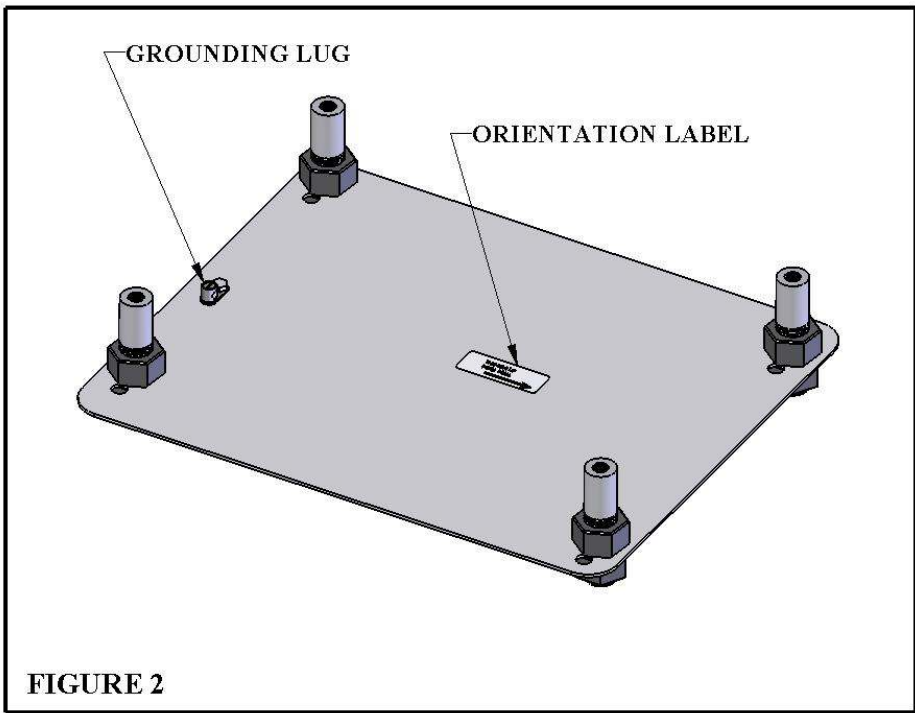

FIGURE 2

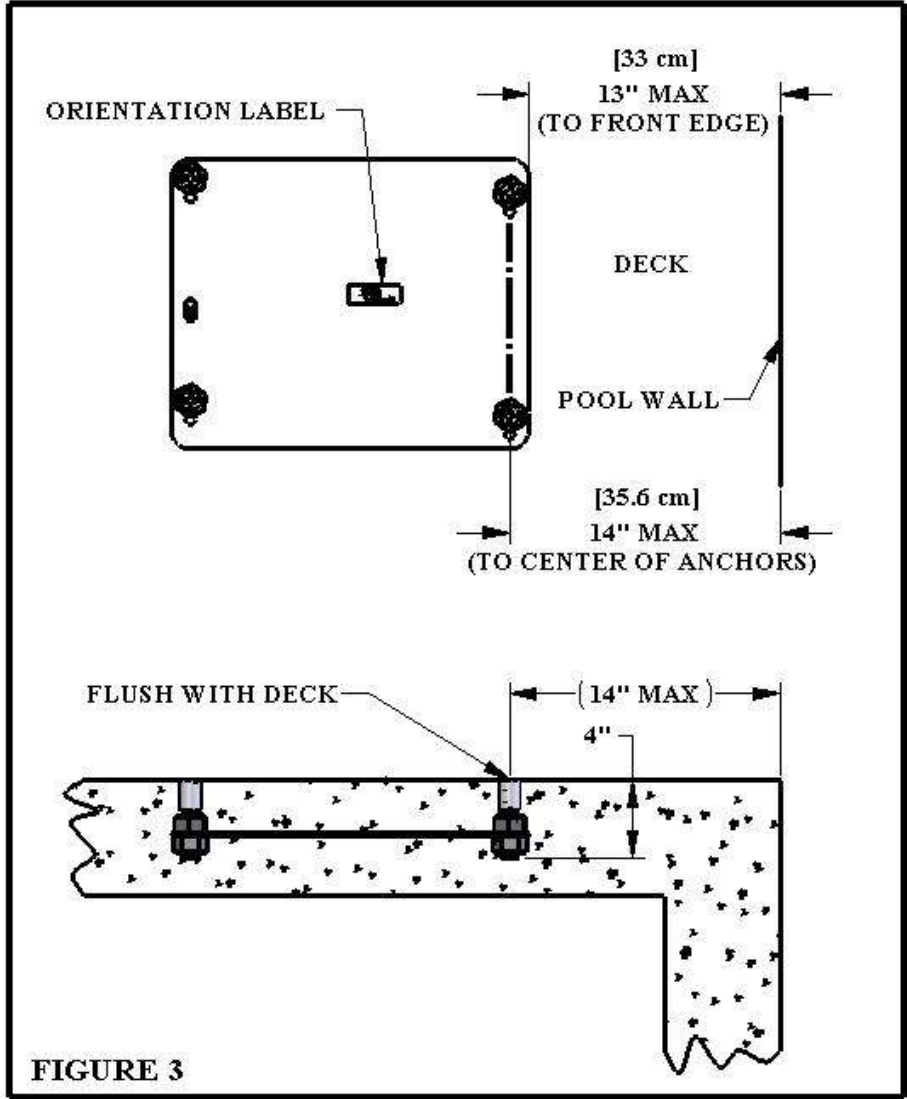
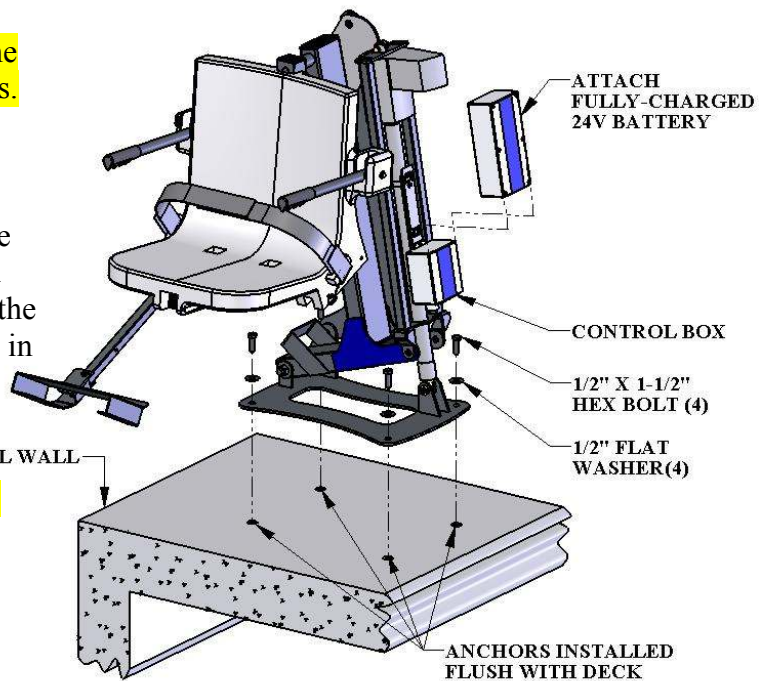
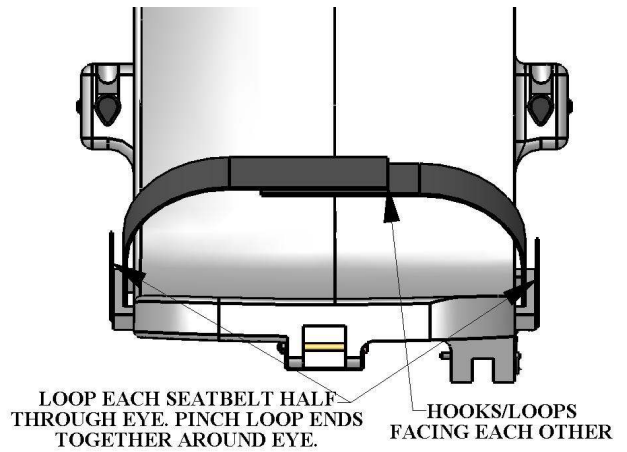

FIGURE 3

PRO POOL LIFT - ASSEMBLY INSTRUCTIONS

1. Attach Seat belt to the seat as shown.
2. Install the PRO POOL LIFT™ onto the four (4) anchors using the supplied 1/2 x 1-1/2" stainless steel hex-head bolts and 1/2" stainless steel flat washers. Make sure all bolts are tight before using the lift.
3. Plug the handset cable into the large handset socket on the bottom of the control box. Be sure you press the cord end firmly into the socket until you are sure it is all of the way into the socket. Failure to fully push the remote cord into the socket may result in faulty or interrupted operation.
4. Before installing the battery, place it on the charging unit and let it charge for 24 hours. Make sure the orange "charge" light illuminates when the battery is being charged.
5. Remove the fully-charged battery from the charger and install it on top of the Control Box. The battery will line up square with the control box, and will 'click' when it locks in place properly. The lift will only operate when the battery is mounted properly.



DO NOT LEAVE THE BATTERY ON THE LIFT! WHEN NOT IN USE STORE THE BATTERY ON THE CHARGER.

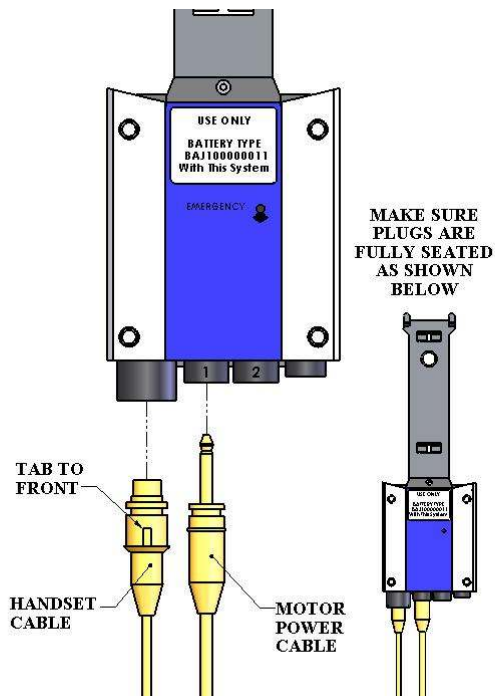

24V BATTERY SYSTEM OPERATING AND INSTALLATION INSTRUCTIONS



24V SEALED BATTERY



WALL MOUNT CHARGER



CONTROL BOX
& HANDSET REMOTE

The Pro Pool Lift™ Battery system comes with a 24v sealed rechargeable battery, wall mount charging unit (with mounting bracket), control box, and a waterproof handheld controller. The control box is mounted to the Pro Pool Lift™ and has a plug-in socket for both the actuator and the handheld controller. The battery mounts directly above the control box with a quick-release clip.

To operate the Pro Pool Lift™, plug in the handheld controller to the control box and push the corresponding button to either lower or raise the unit. The lift should be able to complete approximately 10-20 full cycles before the low battery indicator tone will sound. The low battery tone indicates that there is approximately 20% battery life remaining. At this point, DO NOT ATTEMPT TO OPERATE THE LIFT, remove the battery from the unit and recharge on the wall mounted charging unit.

To recharge the battery, simply grip the top of the battery and depress the clip on the back of the battery. This will unclip the battery from the control box bracket and the battery can then be clipped into the wall mount charger. When the **charger** is plugged in the green **ON** light will illuminate. When the **battery** is correctly mounted to the charger, the orange **CHARGE** light will illuminate. When the battery is fully charged, the **CHARGE** light will **GO OFF** and you can return the battery to the Pro Pool Lift™.

DO NOT LEAVE THE BATTERY ON THE LIFT. WHEN NOT IN USE STORE THE BATTERY ON THE CHARGER.

BATTERY MAINTENANCE

1. **RECHARGE THE BATTERY AS OFTEN AS POSSIBLE.** The battery power unit is a sealed lead acid battery pack. Frequent recharges will prolong the battery life and maintain a high cold amperage capacity.
2. Do NOT expose the battery to freezing temperatures.
3. Do NOT expose the battery to prolonged periods of extreme heat or severe cold temperatures.
4. Do NOT expose the battery to long periods of direct sunlight. Heat will shorten your battery life. Optimum operating temperature is below 20 degrees Celsius (68 degrees F.)
5. Never drop or bump the battery pack. This may result in loose or damaged internal connections, and may bend the battery terminals.
6. Keep battery terminals clean and free from dirt and corrosion to ensure good contact. The terminals may be cleaned using Scotch Brite or any similar product. Clean off any corrosion or discoloration on the very top surfaces of the battery contacts and then apply dielectric grease (supplied with lift) as shown in the figure below.

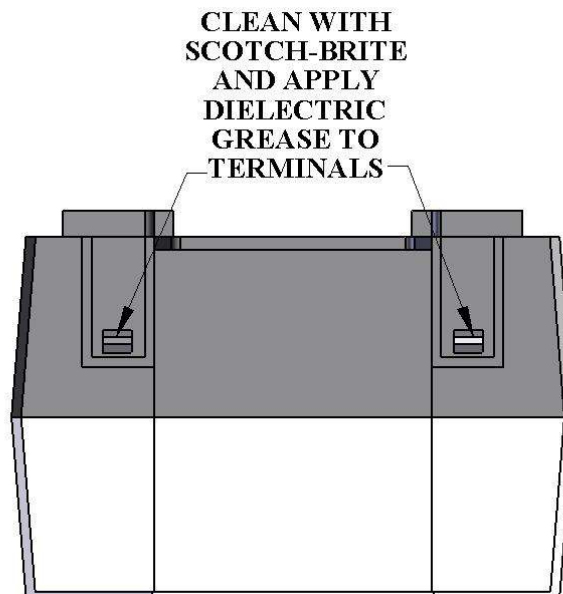

USING THE “EMERGENCY BUTTON” on the Pro Pool Lift Control Box

On the front side of the control box is a small recessed button marked “emergency”. Take a pen or pencil or other pointed object and depress the “emergency” button. This will bypass the remote control and send a signal directly to the actuator to raise the seat out of the pool and back to the deck or up position.

NOTE: This function will only work if there is sufficient power in the battery, the battery is properly attached to the control box, and the control box must be operating properly.



PRO POOL LIFT OPERATING INSTRUCTIONS:

NOTE: CHECK ALL NUTS & BOLTS FOR TIGHTNESS AND FOR WORN PARTS BEFORE EACH USE. NEVER OPERATE THE LIFT WITH THE ARMRESTS FLIPPED UP.

The Pro Pool Lift™ should always be in the full up or deck position before a user attempts to transfer into the chair. Before attempting to transfer into the chair, check to make sure the lift is operating by making a short test run: move the chair at least part way in and out of the pool.

As you are standing in front of the chair, facing the chair, the armrest on either side will flip up to allow for easier lateral transfers. Transfer into the chair and then lower the flip-up armrest back into its normal position. Secure the adjustable lap belt around the waist so that the belt is snug, but not uncomfortably tight.

You are now seated comfortably in the Pro Pool Lift™, and ready to move into the pool or spa. Before you begin the operating cycle, take a visual check of the deck area and pool area to make sure the operating path of the lift is clear.

It is not necessary to lower the lift all the way to the bottom of the lift's stroke. You may stop the lift at any time in the downward cycle when it is comfortable for you to exit the chair into the water.

This is NOT true however, when returning to the deck during the up cycle. The lift should always be cycled completely to the up or deck position before attempting to exit the chair on the deck.

To lower the lift into the pool, simply apply pressure on the down arrow button on the remote control handset and the chair will start to move towards the pool. NOTE: for safety reasons, it is necessary to maintain continuous pressure on the control button. If you take your finger off of the control button the lift will stop.

When you are sufficiently submerged into the water to allow for an easy exit from the chair, you may stop the lift cycle by releasing pressure on the down arrow button on the remote control handset. Now release the lap belt by grasping the end of the belt that is protruding above the lap belt and tugging gently. You may now flip up the footrest to create more room in front of the chair for you to exit. Exit the chair by sliding straight forward until you are clear of the seat and the footrest.

When you are ready to return to the lift seat and exit the pool or spa, make sure that the chair is lowered (submerged) sufficiently to allow you to easily slide into the chair. You should not attempt to "lift" or raise yourself into the chair. Once you are reseated into the chair, you may lower the footrest to its normal operating position and place your feet on the footrest. Next, re-secure the adjustable lap belt snugly around your waist. To raise the chair out of the pool, simply press on the up arrow button on the remote control handset and apply continuous pressure until the lift chair comes to a rest on the deck in the full up position. You may now release the lap belt and exit the chair.

PRO POOL LIFT™ – HEADREST (OPTIONAL)

ITEM #	QTY.	DESCRIPTION
1	1	HEADREST PAD
2	1	HEADREST SUPPORT
3	2	1/8" x 3/4" S.S. SCREW

TOOLS NEEDED:

5/64" DRILL BIT
PHILLIPS SCREWDRIVER

ASSEMBLY INSTRUCTIONS

1. Begin by locating all parts in the above parts list.
2. Attach the headrest pad to the support bar by slipping the cross bar into the sewn supports on the back of the headrest pad.
3. Adjust the height of the headrest for the user and mark the hole locations (**FIGURE 8**).
4. Drill a 5/64 inch [2 mm] hole at the marked locations from step 3.
5. Install the headrest with the supplied stainless steel screws (**FIGURE 8**).



FIGURE 8

SAFETY & MAINTENANCE INSTRUCTIONS

Do not play on or around this lift

1. Check the PRO POOL LIFT™ before each use to assure there are no worn parts and that all hardware is properly tightened. If there are any worn parts, replace them BEFORE using the Pro Pool Lift™. You can call our customer service at 1-888-687-3552 to order any parts.
2. Aqua Creek Products, LLC lifts shall be grounded per local codes.
3. At least ONCE A WEEK, the Pro Pool Lift™ must be cleaned with fresh water. Do not spray the Pro Pool Lift™ 24v battery unit directly with any pressure. Wipe all surfaces clean with a damp, non-abrasive cloth. When cleaning the Pro Pool Lift™, use non-abrasive soap and water. Avoid harsh chemicals and disinfectants.
4. Always read the label instructions on any cleaner carefully before applying it to a surface.
5. The WARNING & INTENDED USE labels on the Pro Pool Lift™ need to be maintained in readable fashion. If they become un readable or faded, please replace the label immediately. Replacement labels are available from AQUA CREEK PRODUCTS LLC. 1-888-687-3552.

CARE OF YOUR LIFT

Routine cleaning is an absolute necessity to ensure the integrity of the lift. Note that the Aqua Creek Pool Lift should not be stored in a pump room or in a storage room where pool chemicals are kept. Storing the lift near pool chemicals may cause rusting and other damage to occur. Your Aqua Creek stainless steel lift is powder coated to protect the stainless steel from rusting. Most rusting will occur at weld points, crevices, under gaskets, rivets or bolt heads.

The choice of a proper cleaning product is up to the consumer and there are many to choose from. Depending on the type of cleaning and the degree of contamination (rusting), some products are better than others. For routine cleaning the products most recommended are gentle soaps or detergents or dilute mixtures of ammonia. For stubborn spots and stains try using soft scrub with some brisk rubbing.

DO NOT USE POOL WATER TO CLEAN USE ONLY FRESH WATER

If the lift is used **DAILY** make sure to wash the lift at the end of the day. Wash the lift off using a mild soap and a soft cloth. Make sure to pay special attention to weld points and crevices. Do not use a bristled brush or steel wool to clean the lift. Check that the lift is working properly and then place the battery on the charger. It is recommended that the battery be charged after every day of use.

If the lift is used **WEEKLY** follow the same steps as above. Also be sure to check all of the contact points (terminals) for damage or corrosion. If you notice corrosion gently clean the terminals. To clean corrosion from the terminals use a q-tip and some rubbing alcohol. If the corrosion is particularly stubborn try using a 3M scotch brite pad, but be careful not to damage the terminals. Apply dielectric grease to the terminals after cleaning them. This will help to prevent further corrosion. Do not leave the battery on the lift. Always store the battery on the charger whenever the lift is not being used.

If the lift is used **MONTHLY** follow the same steps as above. Also check the nuts and bolts to make sure they are securely fastened (this is always a good idea, no matter how often or infrequently the lift is used). Also make sure to store the battery on the charger and not on the lift. Leaving the battery on the lift for extended periods will significantly shorten the battery's lifespan.

If the lift is being **STORED** for an extended period of time follow all of the steps above. Check for rusting at all crevice and weld points. If you notice rusting spray some WD-40 on the affected area and take a 3M scotch brite pad and rub briskly. Afterwards be sure to wash and rinse the lift again with soap and water. When storing the lift make sure it is in a dry area and covered. **DO NOT STORE** in or around pool chemicals.

TROUBLESHOOTING GUIDE

Before troubleshooting make sure the battery is fully charged.

If the lift doesn't move when the handset button is pressed:

When you can't get the lift to move check the following things:

1. Make sure the battery is fully charged:
 - A. Before charging the battery first make sure the **green** light on the front of the charger is illuminated (this means that the charger is on). Then check to make sure the silver contact points on the battery and charger are not damaged or corroded, and that they are clean. Then place the battery on the charger and look for the **orange** charge light to illuminate on the front of the charger. When the orange light goes off the battery is fully charged.

The top **green light** will always be illuminated indicating that it has power. When charging the battery the bottom **orange light** will illuminate, until fully charged.



- B. When the battery is correctly installed on the charger or control box you should hear a “click” indicating the battery is properly seated on the unit. Also note that when the battery is properly seated there should not be any gaps between the battery and the control box/charger.



Not attached properly. Note the white bracket is in front of silver clip, which will not allow for an electrical connection.



Properly Attached. Note that the white bracket is behind the silver clip. Not allowing movement.

If the battery is fully charged and the lift is not moving then:

2. Check all cords:

- A. Check that the cords are properly plugged in. Start by unplugging the remote and the actuator cord from the control box. Once these cords are removed check the ends for corrosion or damage. Plug the remote cord back in by lining up the raised tab on the plug to the grooved line on the control box outlet. Note that these cords require some force to plug them in fully. You will know they are correctly inserted when you hear a “popping sound”. The cords will be recessed into the outlet. If they are flush with the outside of the outlet they are not plugged in fully and the lift will not function. Make sure you do this for both cords.



NOT inserted fully.



Fully inserted.

If you have checked all the cords and the lift still doesn't move:

3. Check the contact points:

- A. After you have fully charged the battery and checked the cords to make sure they are properly plugged in, check to make sure the contact points are not corroded or bent. If the contact points are corroded take some rubbing alcohol and a q-tip and clean off the points. After cleaning the contact points it is recommended to put some dielectric grease on the contact points (terminals) to help ensure good electrical contact and prevent corrosion. Then reinstall the battery on top of the control box. Make sure you hear a “click”, which indicates that the battery is correctly seated. The lift will not work if the battery is not seated correctly.

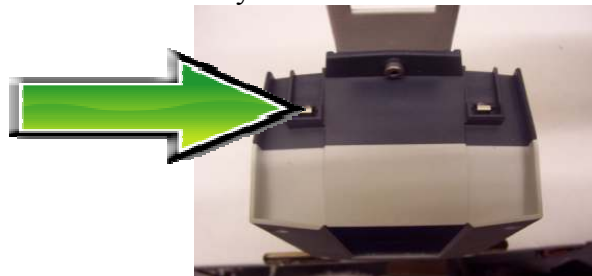

Silver tabs are the contact (terminal) points.

If the lift stops moving over the water and is stuck:

4. Then try pushing the emergency button:

A. If the lift gets stuck out over the water use a pen or pencil tip and stick it into the emergency button on the front of the control box to retract the lift. Note the lift will not retract if the battery is not fully charged or if the control box is not working. The emergency button only overrides the remote in case it has gone bad. If this does not retract the lift then chances are the remote is fine and you either have a problem with the battery, the control box, or the cords are damaged or not plugged in properly.

Use a pen or pencil tip to push in the small black circle located next to the word **emergency**, on the front of the control box.



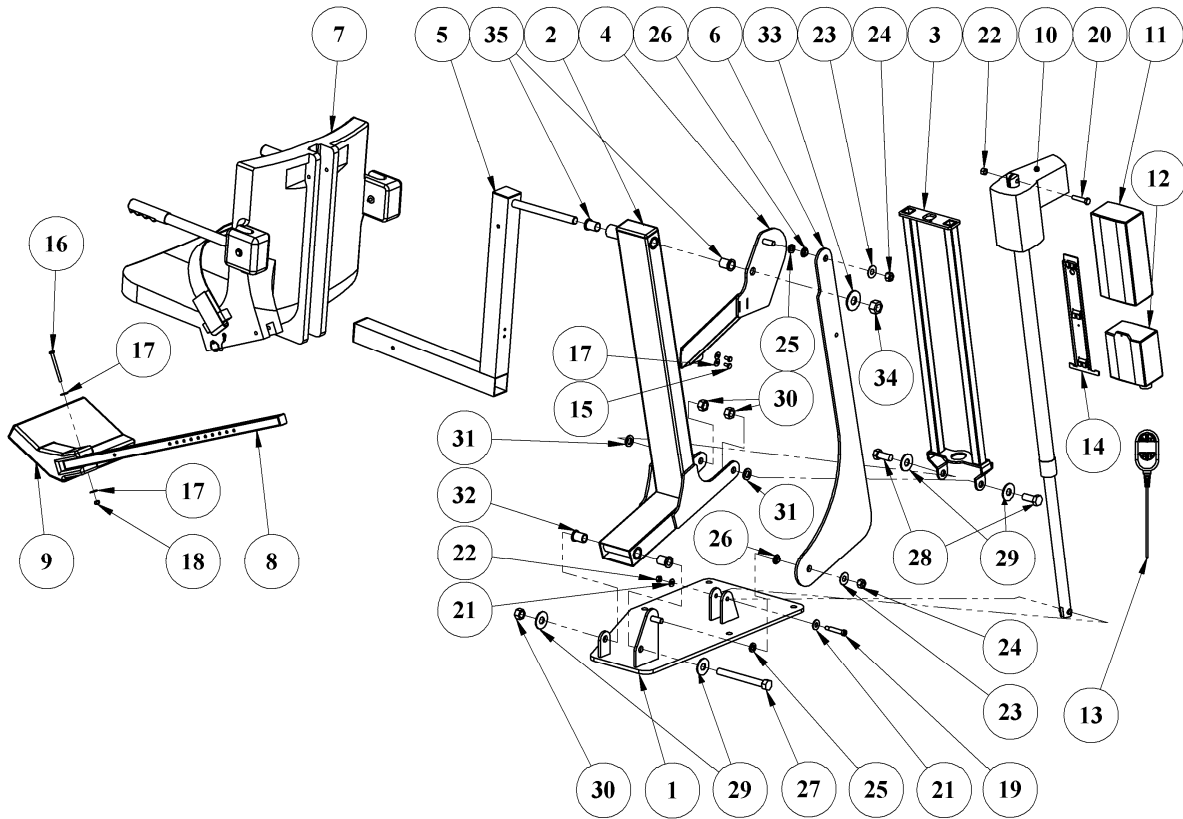

PRO POOL EXTENDED BASE: PARTS LIST

ITEM #	QTY	DESCRIPTION	PART NUMBER
1	1	PRO POOL EXTENDED BASE	A-2011PPB-26
2	1	PRO POOL FRAME	SA-0404PPF
3	1	PRO POOL ACTUATOR FRAME	SA-8980PPAF
4	1	PRO POOL SEAT SUPPORT ARM	P-2012SRS
5	1	PRO POOL SEAT ARM	SA-2012ARM
6	1	PRO POOL CONTROL ARM	L-2014FBL R3
7	1	CHAIR ASSEMBLY	(SEE NEXT PG)
8	1	FOLDING FOOTREST TUBE	MACH-P-2035LEG
9	1	FOLDING FOOTREST	P-910
10	1	LINEAR ACTUATOR	F-499BAS
11	1	24 VDC LEAD-ACID BATTERY	F-004AB
12	1	CONTROL BOX	F-40CBJ
13	1	HANDSET CONTROL	F-100JH
14	1	BATTERY/CB BRACKET	MBJ2-01
15	1	1/4"-20 x 1/2" HEX BOLT, S.S.	BOLT 1/4X1/2SSHEX
16	1	1/4"-20 x 3" HEX BOLT, S.S.	BOLT 1/4X3SSHEX
17	4	1/4" FLAT WASHER, S.S.	FLATWASHER1/4SS
18	1	1/4"-20 NYLOCK NUT, S.S.	NYLOCK1/420SS
19	1	3/8"-16 x 2 1/2" HEX BOLT, S.S.	BOLT 3/8X21/2SSHEX
20	1	3/8"-16 x 1 3/4" HEX BOLT, S.S.	BOLT 3/8X13/4SSHEX
21	2	3/8" FLAT WASHER, S.S.	FLATWASHER3/8SS
22	2	3/8"-16 NYLOCK NUT, S.S.	NYLOCK3/816SS
23	2	1/2" FLAT WASHER, S.S.	FLATWASHER1/2SS
24	2	1/2"-13 NYLOCK NUT, S.S.	NYLOCK1/213SS
25	2	1/2" x 1/8" THRUST WASHER, BRONZE	TW1/2X1/8BRNZ
26	2	1/2" x 1/4" FLANGE BEARING, BRONZE	FB1/2X1/4BRNZ
27	1	5/8"-11 x 6" HEX BOLT, S.S.	BOLT 5/8X6SSHEX
28	2	5/8"-11 x 1 1/2" HEX BOLT, S.S.	BOLT 5/8X11/2SSHEX
29	4	5/8" FLAT WASHER, S.S.	FLATWASHER5/8SS
30	3	5/8"-11 NYLOCK NUT, S.S.	NYLOCK5/811SS
31	3	5/8" x 1/8" THRUST WASHER, BRONZE	TW5/8X1/8BRNZ
32	2	5/8" x 1 1/8" FLANGE BEARING, BRNZE	FB5/8X11/8BRNZ
33	1	3/4" FLAT WASHER, S.S.	FLATWASHER3/4SS
34	1	3/4"-10 NYLOCK NUT, S.S.	NYLOCK3/410SS
35	2	3/4" x 1 1/8" FLANGE BEARING, BRNZE	FB3/4X11/8BRNZ

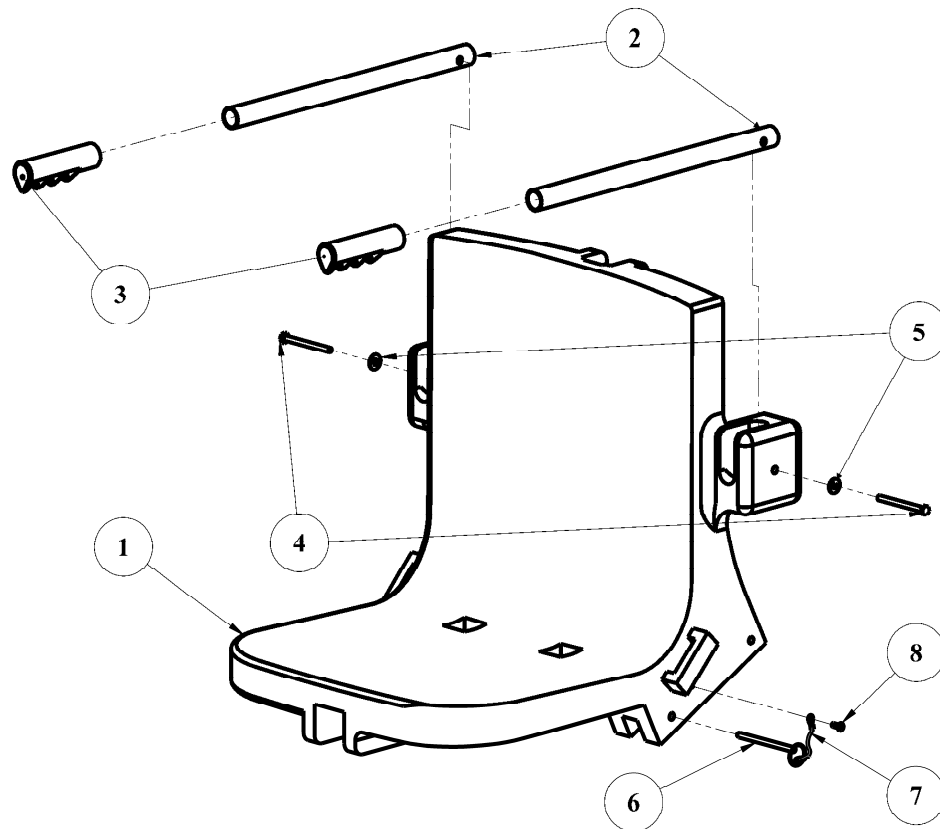

SEAT ASSEMBLY: PARTS LIST

ITEM #	QTY	DESCRIPTION	PART NUMBER
1	1	SEAT BODY	P-900
2	2	SEAT ARMREST TUBE	SA-0904SAT
3	2	SEAT ARMREST HANDGRIP	RUBBERFINGERGRIPS
4	2	1/4"-20 x 3" HEX BOLT, S.S.	BOLT1/4X3SSHEX
5	2	1/4" FLAT WASHER, S.S.	FLATWASHER1/4SS
6	1	1/4" QUICK RELEASE PIN, S.S.	PIN1/4X3SS
7	1	LANYARD FOR QRP	LANYARD
8	1	SHEET METAL SCREW, S.S.	SA-0904SMS

Aqua Creek Products, LLC Limited Warranty:

Pro Pool Lift™ - Reversed Base

Aqua Creek Products lifts have a **Limited Lifetime Warranty** on the frames, not including the powder coat finish. Aqua Creek Products, LLC (a.k.a. Aqua Creek) also warrants to the original end user that all non-frame components manufactured by Aqua Creek, when properly installed in accordance with assembly and installation instructions, and properly used and maintained, shall be free from defects in material and workmanship for a period of five (5) years from the date of original purchase, provided that Aqua Creek receives prompt notice in writing of any defect or failure and satisfactory proof thereof, with the following exceptions:

Exception : All electrical components, including the linear actuator shall have the following warranty period:

Year 1-2: 100% Coverage

Year 3: 60% Coverage (Customer is responsible for 40% of replacement cost)

Year 4: 50% Coverage (Customer is responsible for 50% of replacement cost)

Year 5: 40% Coverage (Customer is responsible for 60% of replacement cost)

This warranty specifically excludes reimbursement for labor to remove, repair, or install the product and any return freight charges.

These warranties do not cover any damages due to accident, misuse, abuse, negligence or failure to properly maintain any products, or normal wear and tear from day to day operations. In the event that any products are altered, repaired, or improperly installed or improperly used by anyone without the prior written approval by Aqua Creek, all warranties are void. **IMPORTANT: AMOUNT OF WEIGHT PLACED ON PRO POOL LIFT SHALL NOT EXCEED THE RATED LIFTING CAPACITY OF 450 POUNDS [204 kg] FOR POOLS WITH WATER DRAFTS OF 6" OR LESS; NOT EXCEED 400 POUNDS [181 kg] FOR POOLS WITH DRAFTS GREATER THAN 6". NEVER OPERATE THE PRO POOL LIFT UNDER LOAD IN A DRY POOL (WITH NO WATER IN THE POOL).**

To initiate a warranty claim, the owner of an Aqua Creek product must provide the place of purchase, in writing, with a full description of the product, its serial number, the dates of purchase and installation, and the exact nature of the defect. Within thirty (30) days after receipt of a written warranty claim by Aqua Creek, and barring any unforeseen delays, the place of purchase will be notified of Aqua Creek's decision regarding the claim.

If requested by Aqua Creek, any defective product must be returned, freight prepaid, to Aqua Creek's designated factory location or duly appointed distributor for inspection and/or repair. Aqua Creek will, at its option, repair or replace the failed or defective item, and deliver the repaired product or replacement to the buyer of the product, freight prepaid to the destination provided for in the original order. Products returned to Aqua Creek for which Aqua Creek provides replacement under this limited warranty shall become the property of Aqua Creek.

A new warranty period shall NOT be established for the repaired or replaced products. Such products shall remain under warranty only for the remainder of the original warranty period on the original products purchased.

This written limited warranty constitutes the final, complete and exclusive statement of warranty terms. No person or organization is authorized to make any other specific or implied warranties or representations on behalf of Aqua Creek.

THE WARRANTIES SET FORTH HEREIN ARE IN LIEU OF ALL OTHER WARRANTIES, EXPRESSED OR IMPLIED, WHICH ARE HEREBY DISCLAIMED AND EXCLUDED, INCLUDING WITHOUT LIMITATION ANY WARRANTY OF MERCHANTABILITY OR FITNESS FOR A PARTICULAR PURPOSE OR USE.

THE SOLE AND EXCLUSIVE REMEDIES FOR BREACH OF ANY AND ALL WARRANTIES WITH RESPECT TO THE PRODUCTS SHALL BE LIMITED TO REPAIR OR REPLACEMENT AT AQUA CREEK'S DESIGNATED FACTORY LOCATION, OR DULY APPOINTED DISTRIBUTOR, OR IN PLACE AT AQUA CREEK'S OPTION. IN NO EVENT SHALL AQUA CREEK'S LIABILITY EXCEED THE ENTIRE AMOUNT PAID TO AQUA CREEK BY THE ORIGINAL PURCHASER FOR THE FAILED OR DEFECTIVE PRODUCT.

IN NO EVENT SHALL AQUA CREEK PRODUCTS, LLC BE LIABLE FOR ANY INCIDENTAL, CONSEQUENTIAL, SPECIAL, INDIRECT, PUNITIVE OR EXEMPLARY DAMAGES OR LOST PROFITS FROM ANY BREACH OF THIS LIMITED WARRANTY OR OTHERWISE.

Aqua Creek Products
9889 Garrymore Lane
Missoula, MT 59808

